



American Hakko Products, Inc.

PRODUCT BULLETIN

Bulletin No: PB363

Issue Date: 6-02-2015

Available: 7-14-2015

Product Description:

HAKKO T31-xx Series Soldering Iron Tips

Part No:

T31-011401, T31-011402

T31-021401, T31-021402



Specification:

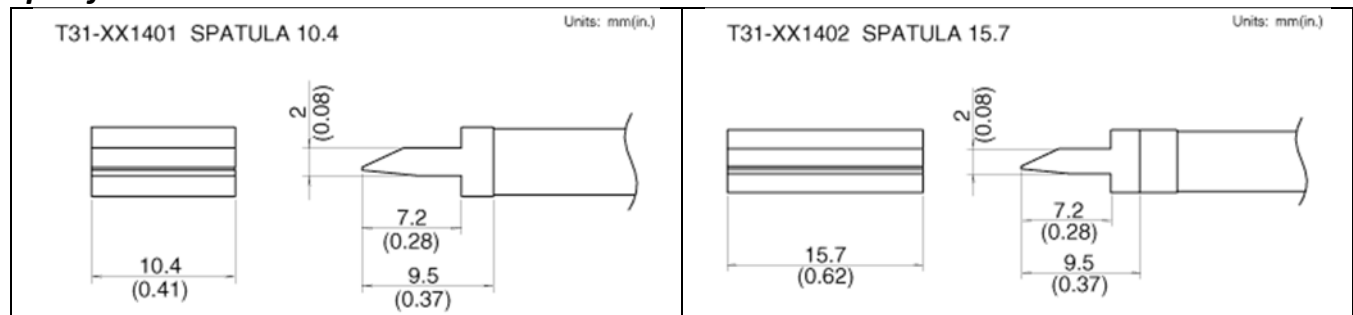

NOTE: xx:01 = 450°C (840°F) | xx:02 = 400°C (750°F)

Comments:

Two very popular spatula shape tips have been added to the T31 Series of tips for the exclusive use with the HAKKO FX-1001 Soldering Iron Handpiece. They use a highly precise manufacturing and process control method that allows for a more repeatable tip temperature between not only the same tip shape, but even between tips of different shapes but within the same series.

These tips are generally used for the simultaneous soldering of a multiple leads along one side of an SMT component, or when used with desoldering wick, the removal of residual solder from a BGA component site. They are also used for soldering RF shielding found on some PCBs and other hot bar type applications.

For more information please visit us at www.HakkoUSA.com